DPR300 Pulser/Receiver Operator Manual

February, 2011



JSR  **Ultrasonics**

www.JSRUltrasonics.com

Copyright © 2006-2011 Imaginant Inc. All Rights Reserved

0000 0200 1006 D

Table of Contents

| | | |
|----------|--|-----------|
| 1 | Fuse, Safety, and Technical Support Information | 4 |
| 2 | Fuse Information..... | 4 |
| 2.1 | Safety | 4 |
| 2.2 | Technical Support | 4 |
| 2.3 | Cleaning | 4 |
| 3 | Warranty Agreement | 5 |
| 3.1 | Instrument Limited Warranty..... | 5 |
| 3.2 | Software Limited Warranty | 5 |
| 3.3 | Application Disclaimer | 5 |
| 4 | General Description..... | 6 |
| 4.1 | Description..... | 6 |
| 4.2 | Physical..... | 7 |
| 5 | Theory of Operation | 8 |
| 5.1 | DPR300 Subsystems and Their Functions..... | 8 |
| 6 | Controls, Indicators, and Connectors | 11 |
| 7 | Instrument Setup | 15 |
| 7.1 | System Components..... | 15 |
| 7.2 | Mains Disconnect..... | 15 |
| 7.3 | Earth Ground..... | 15 |
| 7.4 | Computer Requirements | 15 |
| 7.5 | System Configuration | 15 |
| 8 | Operation..... | 16 |
| 8.1 | Pulse-Echo Mode Operation | 16 |
| 8.2 | Transmission Mode Operation..... | 16 |
| 8.3 | Operating the DPR300..... | 17 |
| 9 | Remote Operation of the DPR300 | 19 |
| 9.1 | Overview of Remote Operation | 19 |
| 9.2 | JSR Control Panel graphical user interface..... | 20 |

| | | |
|-----------|---|-----------|
| 9.3 | JSR Common SDK (Software Development Kit)..... | 21 |
| 9.4 | JSR Simple ActiveX object..... | 22 |
| 9.5 | Remote PC control via serial port commands..... | 22 |
| 9.6 | COM Port Configuration | 22 |
| 9.7 | PRF Control | 23 |
| 10 | Pulser..... | 23 |
| 10.1 | Receiver | 24 |
| 10.2 | PC or Compatible Control Computer..... | 24 |
| 10.3 | Environmental Conditions | 25 |
| 10.4 | Miscellaneous | 25 |

1 Fuse, Safety, and Technical Support Information

2 Fuse Information

The DPR300 utilizes .25A 250V 3AG-type slow-blow glass-cartridge fuses.

Warning Fire Hazard. Replace fuses only with fuses of the same type and rating.
Warning: Shock hazard. Disconnect electric power before replacing fuses.

2.1 Safety



There are no user serviceable parts in the DPR300, other than the fuse. DPR300 units should be returned to the manufacturer for any repair.



If the DPR300 is not used as prescribed by the manufacturer, the overall safety may be impaired.



Ensure that the power cord is appropriate before connecting the DPR300 to mains power. Use a power cord rated for the mains voltage, preferably a power cord supplied by the equipment manufacturer or authorized agent.

2.2 Technical Support

The answers to most questions regarding the use of the DPR300 Pulsar/Receiver are contained in this manual. If you cannot find an answer to a question, please contact JSR Ultrasonics technical support at:

Imaginant Inc.
3800 Monroe Ave.
Pittsford, NY 14534

Voice: +1 585 264 0480
Fax: +1 585 264 9642
E-mail: TechSupport@Imaginant.com

2.3 Cleaning

The DPR300 does not require any special cleaning.

3 Warranty Agreement

3.1 Instrument Limited Warranty

Imaginant Inc. warrants that its instruments will be free from defects in materials and workmanship for a period of one year from the date of purchase. Imaginant will, at its option, repair or replace any of its products that prove to be defective during the warranty period without charge for parts and labor.

To obtain service under this warranty, the Customer must ship the defective product to Imaginant with the shipping charges prepaid. The Customer will be responsible for packaging the defective product, preferably in the original packaging materials.

The warranty does not apply to any defect, failure, or damage caused by improper usage, handling, care, or tampering. Neither will this warranty apply to any equipment damaged from attempts by personnel other than Imaginant to repair or modify the product.

Imaginant disclaims any warranty, either express or implied, as to the applicability or fitness of its hardware or software for a particular purpose or application. Imaginant will not be liable for any direct, indirect, incidental, or consequential damages related to the use of its products regardless of whether Imaginant received any advance notice of the possibility of such damages.

3.2 Software Limited Warranty

Imaginant Inc. warrants for a period of 120 days from the date of delivery that its instrument control software will perform under normal usage and without unauthorized modification substantially in accordance with the specifications published in the documentation and those set forth in Imaginant advertising material. Imaginant also warrants that, under normal use, the media upon which this program is recorded is not defective; and that the user documentation is substantially complete and contains the information Imaginant deems necessary for using its software. If during the 120-day warranty period a demonstrable defect in the program or documentation should appear, Imaginant will repair or replace the software with functionally equivalent software within 30 days after Imaginant has been notified of such a defect.

Imaginant disclaims any warranty, either express or implied, as to the applicability or fitness of its software for a particular purpose or application. Imaginant will not be liable for any direct, indirect, incidental, or consequential damages related to the use of its products regardless of whether Imaginant received any advance notice of the possibility of such damages.

3.3 Application Disclaimer

This product is not intended or designed for use in medical or other devices or systems where malfunction of this product can reasonably be expected to result in personal injury. Imaginant customers using or selling this product for use in such applications do so at their own risk and agree to fully indemnify Imaginant against any damages resulting from such improper use or sale.

4 General Description

4.1 Description

The DPR300 is a general-purpose ultrasonic pulser/receiver that can be configured for a wide range of uses. In addition to describing available DPR300 features and options, this manual indicates the differences between the available DPR300 configurations.

The DPR300 can be configured during manufacture as a pulser/receiver with manual-only control, PC control, or simultaneous manual and PC control. For DPR300 units populated with both front panel and remote PC controls, the instrument responds to both sets of controls, and each instrument function will be set to the value most recently received from the front panel or remote command.

The DPR300 receiver is available in 35MHz and 50MHz bandwidths, and the DPR300 pulser is available in 475V and 900V amplitude ranges. *Users should familiarize themselves with the operational limits of DPR300 pulsers that have the 900V option installed by reading about the PRF command in Section 6 of this manual.*

In a typical DPR300 application, the DPR300 pulser produces a high voltage electrical excitation pulse and applies this pulse to the instrument's T/R connector. An ultrasonic transducer connected to the T/R connector via a length of 50 Ω coaxial cable is then employed to convert the electrical energy of the excitation pulse into an ultrasonic pulse that is propagated into a test material or medium. Four energy levels, sixteen amplitude levels, and two pulser-impedance values offered by the DPR300 enable the user to adjust the characteristics of the excitation pulse to the specific transducer employed. Sixteen discrete damping levels in the DPR300 allow the transducer response to be adjusted over a wide damping range.

With the DPR300 configured for pulse-echo mode operation, acoustic echoes reflected from interfaces or defects within the test material are converted by the transducer into electrical signals that are presented to the T/R connector of the DPR300. The low-noise DPR300 receiver amplifies these electrical signals, and the signals then pass through adjustable high pass and low pass filters. The DPR300 receiver gain is adjustable between -13 dB and 66 dB, and there are six high pass and six low pass filter settings for band-limiting the receiver frequency response. The amplified and filtered signals are available on the instrument's Receiver Output connector.

The DPR300 may also be used in transmission mode operation wherein a separate receiving transducer is used to detect acoustic pulses that have propagated through a test material or medium. This second transducer is connected to the DPR300 receiver Through connector, and the received signals are processed as described above for pulse-echo mode operation.

The DPR300 allows external equipment such as A/D digitizer boards or oscilloscopes to be synchronized to the pulser operation. To facilitate this, a synchronization pulse applied to the Trig/Sync connector can be employed to trigger the pulser when the instrument is in external trigger mode. Alternatively, when the DPR300 is configured for internal-trigger mode, a short pulse is output on the Trig/Sync connector simultaneous with the generation of the excitation pulse. All connectors on the DPR300 are BNC-type with the exception of the computer interface connectors.

4.2 Physical

The DPR300 ultrasonic pulser/receiver is a complete instrument on a stand-alone enclosure. The enclosure dimensions are 12" deep, 8.25" wide, and 3.5" high.

5 Theory of Operation

5.1 DPR300 Subsystems and Their Functions

The DPR300 pulser/receiver is composed of the functional blocks shown in the figure below. These functional blocks include the front panel and remote control hardware, high voltage power supply, pulser, pulser trigger select, PRF oscillator, receiver amplifier, receiver low pass filters, receiver high pass filters, and the RS-232 interface for instruments with the remote PC control option. Instrument control software resides in the remote computer and controls the instrument via the RS-232 serial-interface bus.

DPR300 System Block Diagram

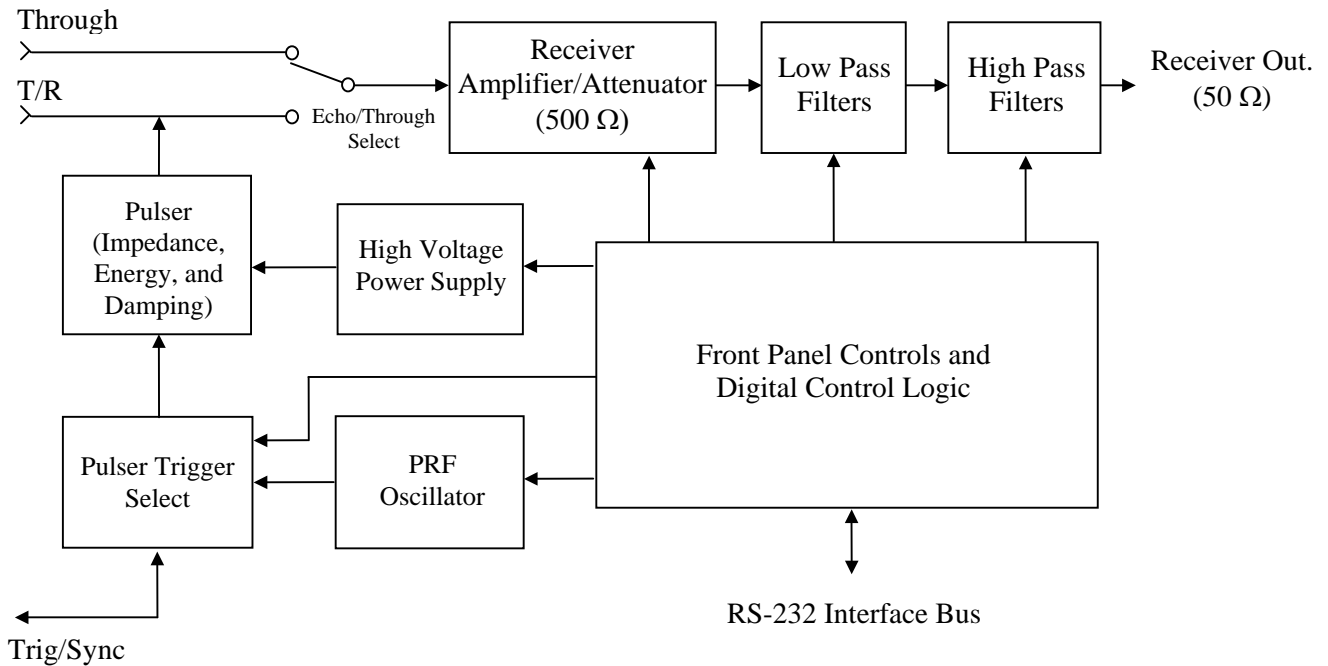

5.1.1 Manual Controls, Digital Control Logic, and RS-232 Interface

The remote control interface and control logic enables the control of the DPR300 from software running on the host computer. Communication is via an RS-232 interface such as the COM1 or COM2 ports on the remote computer. Front panel controls enable manual control of instruments with the manual control option.

5.1.2 High Voltage Power Supply

The precision-regulated high-voltage supply provides power to the pulser. Precise voltage regulation allows the DPR300 pulser to maintain constant pulse amplitude regardless of changes in either the pulse repetition rate or other instrument controls. The voltage may be adjusted from 100V to 475V or from 100V to 900V depending on the pulser voltage option installed.

5.1.3 Pulser (Impedance / Energy / Damping)

The pulser generates an excitation pulse upon receiving a trigger event from a selected source. There are four energy and two impedance values, and the single Energy and Impedance control adjusts the pulse energy and the pulser impedance.

The damping control allows the damping impedance at the pulser output to be set to one of sixteen discrete values.

5.1.4 Pulser Trigger Control

This control selects between the internal PRF oscillator or an external source applied to the Trig/Sync connector as trigger sources for the DPR300 pulser.

5.1.5 PRF Oscillator

The internal PRF oscillator generates repetitive trigger pulses for the pulser subsystem under the control of the PRF control.

5.1.6 Receiver Amplifier

Controls the amplification or attenuation of signals processed by the DPR300 receiver. The receiver gain can be varied from -13 dB to +66 dB. The DPR300 receiver has an input impedance of 500 ohms and is available in both 35MHz and 50MHz bandwidths.

5.1.7 Low Pass Filters

These filters are available for reducing the bandwidth of the DPR300 receiver. High frequency bandwidth limiting can be used to improve the signal to noise ratio for

applications that do not require the full receiver bandwidth. Six low pass filter settings are available in the DPR300, and the exact filter cutoff frequencies depend upon the receiver bandwidth selected.

5.1.8 High Pass Filters

These filters are available for eliminating undesirable low frequency energy from the DPR300 receiver signal. High pass filtering can be used as a means of providing faster receiver recovery from strong signals such as the excitation pulse or strong interface echoes. Six high pass filter settings are available in the DPR300.

6 Controls, Indicators, and Connectors

In this section, the DPR300 ultrasonic pulser/receiver controls, indicators, and connectors are described. The main power switch, power indicator LED, and pulse indicator LED are common to all DPR300. The remaining controls apply only to DPR300 instruments with manual controls. The diagram below shows the locations of the DPR300 front panel controls.

DPR300 Front Panel (with Manual Controls)

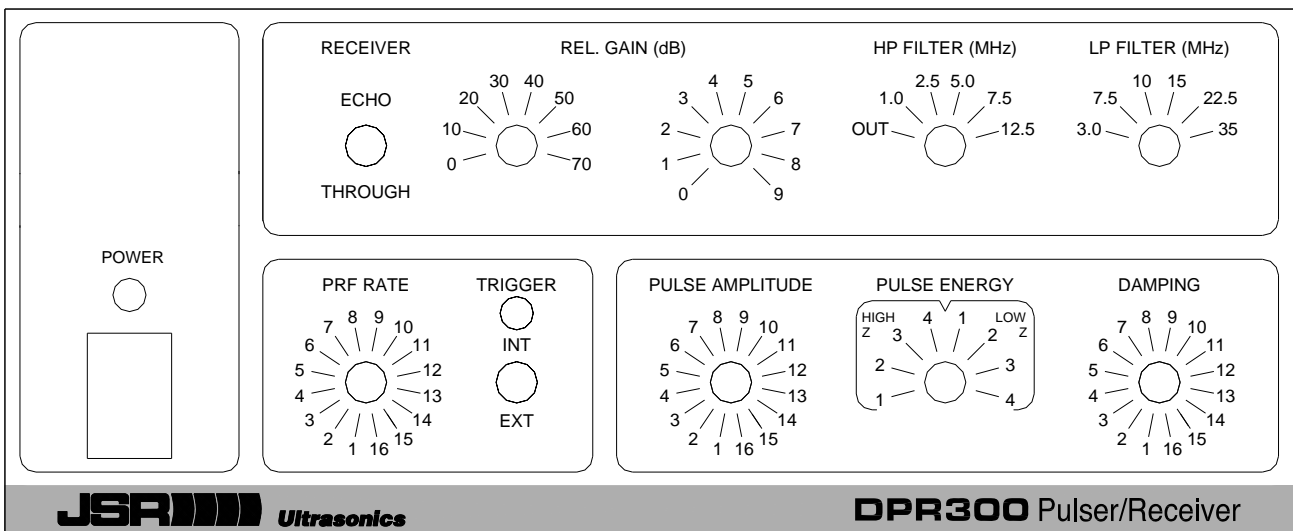

6.1.1 Main Power Switch

A push button switch for turning on/off power to the DPR300.

6.1.2 Power Indicator LED (Power)

An amber-colored LED that lights to indicate that power is applied to the DPR300. This LED can also be made to blink at a controlled rate by the 'Blink' command described in Section 6.

6.1.3 Pulse Indicator LED (Pulse)

This is a red LED indicator that illuminates when the DPR300 pulser is firing.

6.1.4 PRF Control

A rotary switch that selects the frequency at which the pulser fires when internal trigger operation is selected. The PRF values range from 100 Hz to 5 kHz.

6.1.5 Int / Ext Switch

A toggle switch that selects between internal trigger (PRF) and external trigger sources for the pulser.

6.1.6 Echo / Through Switch

A toggle switch that connects the receiver input to the T/R BNC connector or Through BNC connector for Pulse/Echo or Through mode operation respectively.

6.1.7 Rel. Gain Controls

These controls are a pair of rotary switches that set the receiver gain. The receiver gain will be the value indicated by the switches minus 13 dB.

6.1.8 HP Filter Control

This control is a rotary switch that sets the receiver high-pass filter to the value indicated.

6.1.9 LP Filter Control

This control is a rotary switch that sets the receiver low-pass filter to the value indicated.

6.1.10 Pulse Amplitude Control

This control is a rotary switch that sets the amplitude of the excitation pulse generated by the pulser. The amplitude is adjustable between 100V and 475V or 100V and 900V depending on the pulser option installed.

6.1.11 Pulse Energy and Pulser Impedance Control

This control is a rotary switch that sets the energy of the excitation pulse generated by the pulser, and the pulser impedance. This switch combines the pulser energy and pulser impedance functions. The High Z impedance range provides for better transducer damping while the Low Z impedance range provides for better signal strength.

6.1.12 Damping Control

This control is a rotary switch that adjusts the damping applied to the transducer.

The diagram below shows the positions of the connectors on the DPR300 rear panel.

DPR300 Rear Panel Connectors

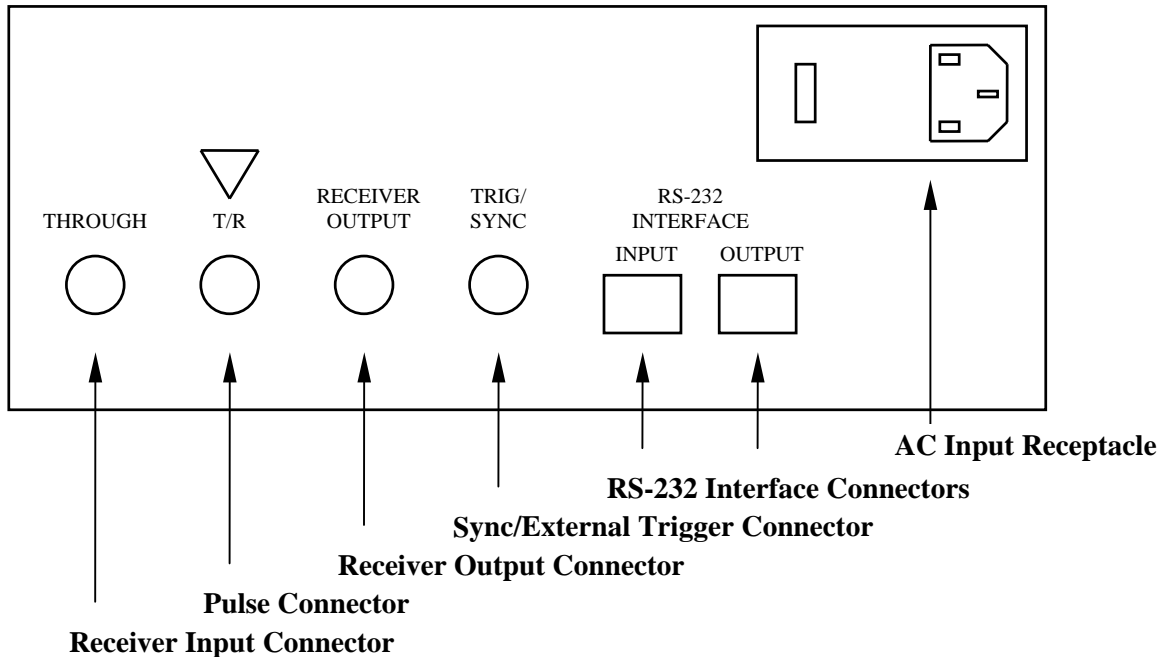

6.1.13 Receiver Input Connector (Through)

This connector is a BNC receptacle for use in connecting receiving transducers to the DPR300 receiver during through-transmission mode operation.

6.1.14 T/R Pulse Connector

A BNC receptacle for connecting to a transmit/receive (T/R) transducer during pulse-echo mode operation, or to a transmitting transducer during through-transmission mode operation.

6.1.15 Receiver Output Connector (Receiver Output)

This connector is a BNC receptacle on which the output signal from the DPR300 receiver is available. This output signal line should be terminated with a 50 Ω load.

6.1.16 Trig / Sync Connector

This connector provides a positive polarity sync pulse signal that can be used to trigger an oscilloscope or other signal monitoring/recording instrument when the DPR300 internal oscillator is used to trigger the pulser. In this mode, the signal line should be terminated with a 50 Ω load.

If the DPR300 pulser is operated in external trigger mode, then the Trig / Sync connector is used for receiving a positive going 3V to 5 V external trigger pulse. Triggering of the pulser will occur synchronously with the rising edge of the trigger pulse.

When triggering the DPR300 pulser from an external source, it is important to ensure that the pulse repetition frequency does not exceed limits defined later in this text.

6.1.17 RS-232 Interface Connectors

These connectors are a pair of RJ45 receptacles through which computer control of the DPR300 is affected on units with the remote PC control option installed. An RS-232 serial-interface port on the control computer is connected to the Input RJ45 receptacle using the eight-conductor reversing RJ45 cable and the DB-9 to RJ45 adapter supplied with the DPR300. When control of other DPR300 instruments is desired, they may be added in a daisy-chain fashion by connecting a reversing RJ45 cable from the RS-232 Output connector on one instrument to the RS-232 Input connector of the next instrument.

6.1.18 AC Input Receptacle

This receptacle is standard power receptacle with fuses. Any supply voltage from 100VAC to 240VAC at 50 Hz or 60 Hz may be applied.

7 Instrument Setup

This section describes requirements for the control computer and the setup procedure for the DPR300.

7.1 System Components

The following system components should be present in your shipment:

- DPR300 Pulsar/Receiver
- DB-9 to RJ45 Adapter (for DPR300 units with remote control function)
- RJ45 Serial Interface Cable (for DPR300 units with remote control function)
- Power Cord
- DPR300 Instruction Manual
- DPR300 Instrument Control Panel Software program on CD ROM

7.2 Mains Disconnect

The power cord is the mains disconnect device. Position the DPR300 such that the instrument can be easily disconnected from the main power supply when needed.

7.3 Earth Ground

Earth ground is connected to the instrument through the power cord.

7.4 Computer Requirements

DPR300 units featuring the remote control option can be controlled by a PC or compatible computer with an available COM1, COM2, or RS-232 serial port.

7.5 System Configuration

1. Locate the power receptacle on the rear of the DPR300.
2. Verify that the fuse values are correct. Pull the fuses out of the power receptacle and verify that they both have value .20A. Slide the proper fuses into the power receptacle and snap the cover closed.
3. For DPR300 units with the computer control option:
 - a) Plug the RS-232 to RJ-45 adapter into the COM1, COM2, or RS-232 serial port on the computer that will be used to control the DPR300.
 - b) Plug one end of the RJ45 serial interface cable into the DB-9 to RJ45 adapter. Plug the other end of the cable into the DPR300 rear connector labeled RS-232 Input.
4. Plug the power cord into the power receptacle on the rear of the DPR300, and plug the other end into a power outlet of the correct voltage.
5. Turn on power to the DPR300 with the front panel power switch.

6. Control the DPR300 using either:
 - a) Manual front-panel controls, or
 - b) The Instrument Control Panel Software program installed and running on a PC or control computer.

8 Operation

8.1 Pulse-Echo Mode Operation

In the pulse-echo mode of operation, a single transducer is used for both pulse generation and echo receiving. To configure the DPR300 for pulse-echo mode operation, the transmit/receive transducer is connected to the rear panel BNC connector labeled T/R, typically via a short length of 50Ω coaxial cable.

The DPR300 pulse-echo mode configuration is shown in the following figure.

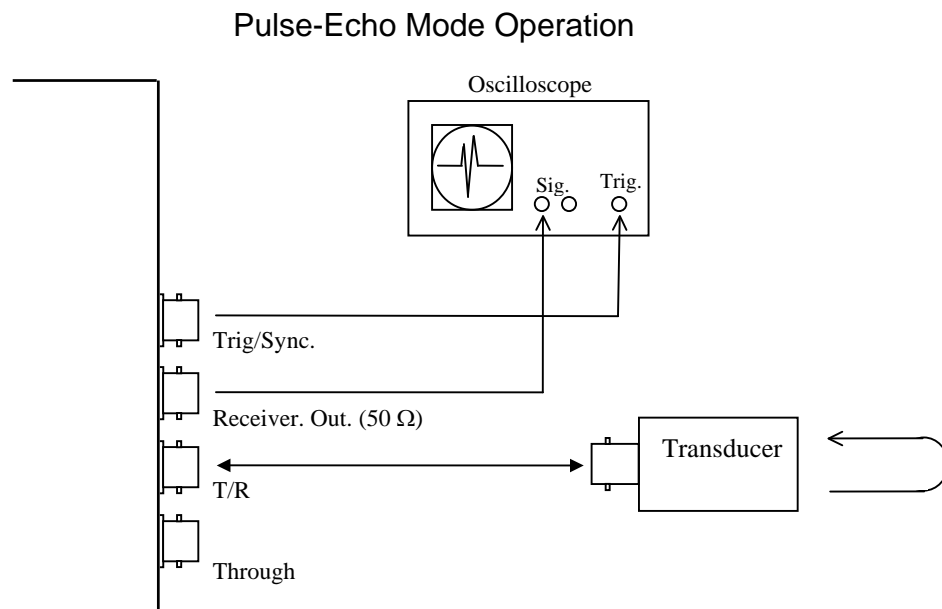

8.2 Transmission Mode Operation

For transmission mode operation, separate transmitting and receiving transducers are employed. The transmitting transducer is connected to the DPR300 T/R connector and the receiving transducer is connected to the Through BNC connector.

The DPR300 transmission mode configuration is shown in the next figure.

Transmission Mode Operation

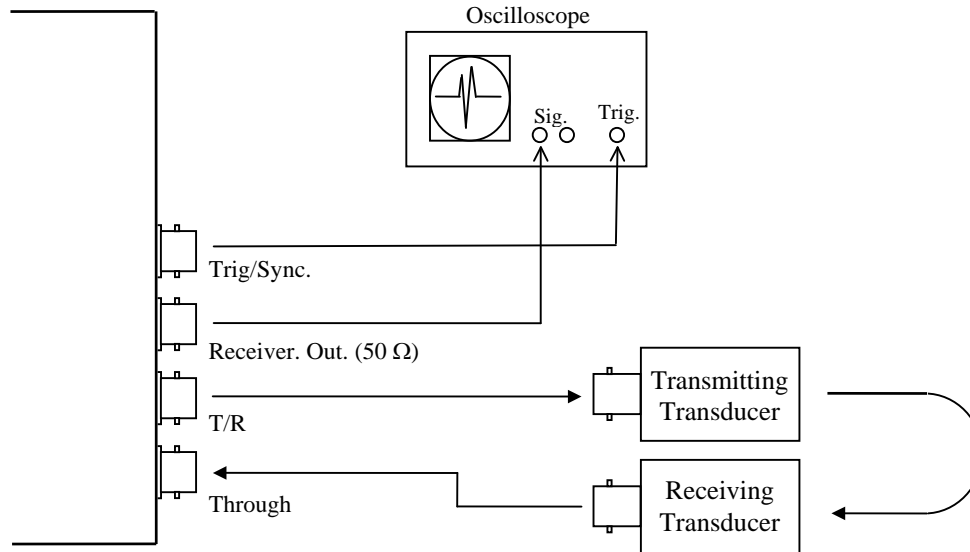

8.3 Operating the DPR300

The following sequence of steps describes a typical operating session with the DPR300.

1. Connect a transmit/receive transducer or separate transmit and receive transducers to the DPR300 as explained above. For contact applications, use a suitable acoustic couplant between the transducer(s) and the sample that is to be tested.
2. Connect the DPR300 BNC connector labeled Receiver Output to the input of an oscilloscope or waveform digitizer via a length of 50Ω coaxial cable. The monitoring oscilloscope or digitizer should have a 50Ω input impedance. If the device input has a high impedance, then a shunt 50 Ω terminator should be added to the input.
3. If a computer is used to control the DPR300, use the supplied software to initialize and control the instrument from a PC or other computer. Otherwise use the front panel controls to control the instrument.
4. Set the pulse trigger control to INT if the DPR300 pulser is to be triggered by the internal PRF oscillator, and connect the DPR300 Trig/Sync connector to the external trigger input of the monitoring oscilloscope. If the DPR300 pulser is to be triggered from an external source such as the synchronization signal of a waveform digitizer, then set the pulse trigger control to EXT and connect both the DPR300 Trig/Sync connector and the external trigger input of the oscilloscope to the source of the external trigger signal. The coaxial cable from the trigger source may be connected to more than one high-impedance load (such as the trigger input of the oscilloscope) but the final connection on the end of the coax cable should be to the DPR300 Trig/Sync connector. The input impedance of the DPR300 Trig/Sync connector is 50 Ω, which serves to properly terminate the trigger signal on the coaxial cable.
5. Using the control software or manual front-panel controls, the instrument may be configured for the operation desired. The red Pulse indicator located on the DPR300 front panel should illuminate when the pulser is firing. Once the pulser is firing, the pulse amplitude (voltage), energy, and damping may be adjusted to match the transducer requirements. In addition, the

pulse repetition frequency (PRF) should be adjusted such that all echoes from any previous excitation pulses have subsided before a new excitation pulse is generated.

6. Adjust the gain control to obtain a signal level between $\pm .2$ and $\pm .5$ Volts peak into a 50Ω load at the SIG OUT connector.
7. Adjust the high and low pass filter cutoff frequencies as necessary. High pass filters can be used to speed amplifier recovery from the main excitation pulse or large interface echoes. For the low pass filter, the cutoff frequency can be reduced in order to improve the signal to noise ratio in low frequency applications.

9 Remote Operation of the DPR300

9.1 Overview of Remote Operation

DPR300's can be purchased in three different configurations: front panel control only, remote PC control only, or with both front panel and remote PC control. This section describes software for controlling one or more DPR300 instruments that have either remote PC control interface option.

DPR300 units that possess both a front panel control option and a remote PC control interface will respond to both sets of controls with each instrument function taking the function value last received from either the front panel or remote PC. When the PC software first connects to a DPR300, the settings on the front panel controls will be read into the PC software and used without change.

Communication between the control computer and DPR300 is via an RS-232 interface using the COM1 or other RS-232 serial port on a control computer. Commands are issued by the control computer and consist of a sequence of bytes transmitted via the RS-232 interface to the DPR300.

A DPR300 can optionally be connected to the control computer with a USB to RS-232 dongle, with the RS-232 side connected to the DPR300 and the USB side connected to the control computer. The software on the PC will work with either a hardware COM port or a USB to RS-232 dongle configured as a virtual COM port. The software will also work with a combination of both hardware COM port and USB dongle if more than one instrument is connected.

Multiple DPR300 instruments may be connected in a daisy-chain fashion to one serial port on the control computer. A command sent by the computer will be received by all instruments in the daisy chain, and acted upon by only the addressed instrument(s). If a DPR300 in the daisy chain is turned off, it will not impede communication between the computer and other instruments. Up to 255 instruments may be connected to one serial port. All instruments may be controlled independently through the assignment of individual addresses. DPR500 instruments can be daisy-chained with DPR300's.

Alternatively, each DPR300 could be connected to its own COM port on the control computer.

Imaginant provides several levels of software for remote PC control, described below.

9.2 JSR Control Panel graphical user interface

JSR Control Panel is a Windows-based application that allows the user to control any number and mix of DPR300, DPR500, and PRC50 instruments.

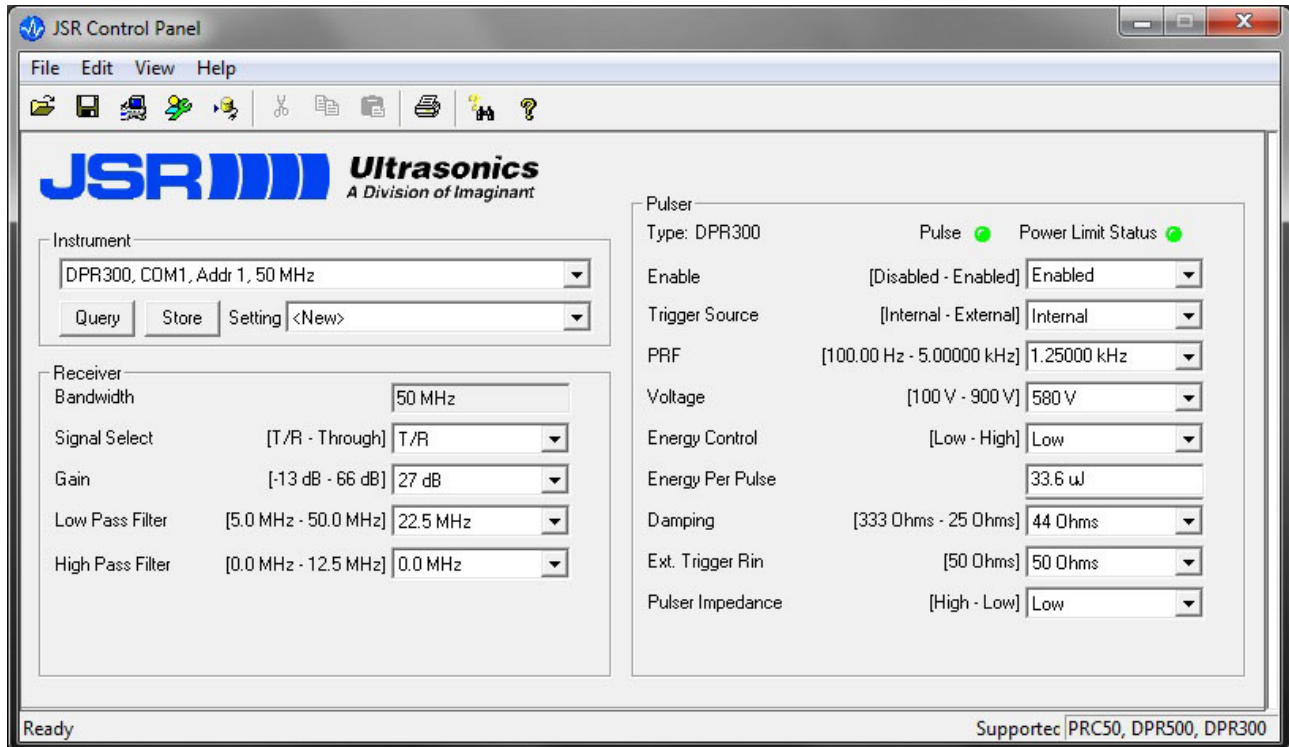

Features of JSR Control Panel software

- Automatically performs daisy-chain or multiple COM port connection
- Configurations of settings can be named, saved, and restored
- Displays allowed ranges of settings in physical units
- Displays and controls current settings
- Query button allows refresh of all values from front panel changes
- Controls any number and mix of DPR300, DPR500, or PRC50 instruments
- Operates on Windows 2000, Windows XP, Windows Vista, or Windows 7 systems.
- Can operate in simulate mode to test before purchasing an instrument.

9.3 JSR Common SDK (Software Development Kit)

The JSR Common SDK provides the tools for a programmer to write application-level programs to control DPR300, DPR500, and PRC50 instruments without having to learn the intricacies of the command protocol, features, or control ranges of the instruments.

The JSR Common SDK consists of:

A set of DLL's

Drivers and files specific to the PRC50 (Windows 2000 and XP only)

Header files

Sample source code and projects

JSR Common SDK Programmer's Reference Manual

JSR Common SDK Properties Reference Manual

Features of the JSR Common SDK

- The same DLL's are used by JSR Control Panel, ensuring compatibility
- Controls any number and mix of DPR300, DPR500, or PRC50 instruments
- Baseline controls for all 3 instruments are the same. E.g volts, PRF, damping, etc.
- Extended controls are provided for features unique to a specific model
- Automatically performs daisy-chain or multiple COM port connection
- Allows control and display of settings in physical units
- Range-checks all commands, providing descriptive error messages
- Error messages can be numeric or text strings
- Can operate in simulate mode to allow code development before purchasing an instrument.
- Operates on Windows 2000, Windows XP, Windows Vista, or Windows 7 systems.
- Application code can be in C or C++.

The JSR Common SDK has an extended property JSR_ID_InstrumentFrontPanelEnables available only on the DPR300. That property allows an application program to disable front panel controls individually. For example, you may wish to have the front panel receiver filters commanded to specific settings but allow the front-panel user to control all other settings. Your software would command the specific settings and command the front panel filter controls to be disabled, leaving all other front panel controls enabled. That would allow your application to prevent an inexperienced operator from accidentally changing the filter controls. See the JSR SDK Properties Reference for more details.

9.4 JSR Simple ActiveX object

The JSR Simple ActiveX object is a thin layer of software that can be used between your application code and the JSR Common DLL. It therefore implements the same functionality as the JSR Common DLL, but has a more modern interface that is easier to use.

Features of the JSR Simple ActiveX object

- Application code can be written in any of several languages:

Visual Basic
C# (C Sharp)
C++

- Use of ActiveX properties makes coding simpler and easier to read:

For example

```
MyPulser.PRF = 2500;  
VoltsToDisplay = MyPulser.Volts;
```

9.5 Remote PC control via serial port commands

When the DPR300 was first introduced, the JSR Common SDK and JSR Simple ActiveX object did not exist. Application developers had to work with the lowest level serial port protocol, which was complicated and dedicated to the DPR300 only.

Documentation of that protocol is not included in this newer manual in order to encourage developers to use either of the two modern interfaces described above.

If you wish to have a copy of the manual that describes the serial port protocol, please write to TechSupport@JSRUltrasonics.com.

9.6 COM Port Configuration

The RS-232 serial port on the control computer should be configured to 4800 baud with 1 start bit, 8 data bits, one stop bit, no parity, and no flow control. An adapter is supplied to convert the DB-9 serial port connector on a PC to an RJ45 receptacle. An RJ45 reversing eight-conductor cable is then used to connect from the serial port to the RS-232 input connector on the DPR300. The pin assignment of the DPR300 rear panel RS-232 interface connectors is shown below.

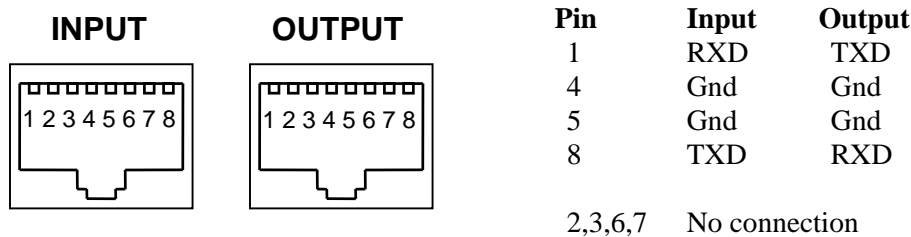

9.7 PRF Control

This PRF control, either via the front panel or from software on a PC, selects the pulse repetition frequency (PRF) of the pulser when internal triggering is selected.

Values in Hz. corresponding to the PRF function values (index) from 0 to 15 are, respectively, 100, 200, 400, 600, 800, 1000, 1250, 1500, 1750, 2000, 2500, 3000, 3500, 4000, 4500, and 5000. This semi-logarithmic sequence provides greater precision in the pulser firing rate at lower frequencies.

DPR300 instruments with the 900V pulser option automatically limit the PRF when the instrument is operating in internal-trigger mode so as to protect the pulser against excess power dissipation. The applied PRF limit depends upon the pulser voltage and energy settings. The following table expresses the recommended maximum PRF index as a function of the pulser voltage index and the pulser energy index.

| | | Pulser Voltage Index | | | | | | | | | | | | | | | |
|--------------|---|----------------------|----|----|----|----|----|----|----|----|----|----|----|----|----|----|----|
| | | 0 | 1 | 2 | 3 | 4 | 5 | 6 | 7 | 8 | 9 | 10 | 11 | 12 | 13 | 14 | 15 |
| Energy Index | 0 | 15 | 15 | 15 | 15 | 15 | 15 | 15 | 15 | 15 | 15 | 15 | 15 | 15 | 15 | 12 | 11 |
| | 1 | 15 | 15 | 15 | 15 | 15 | 15 | 15 | 15 | 15 | 15 | 15 | 15 | 15 | 13 | 11 | 9 |
| | 2 | 15 | 15 | 15 | 15 | 15 | 15 | 15 | 15 | 15 | 13 | 12 | 11 | 10 | 9 | 8 | 7 |
| | 3 | 15 | 15 | 15 | 15 | 15 | 15 | 13 | 12 | 10 | 9 | 8 | 7 | 6 | 5 | 4 | 4 |

Maximum Recommended PRF Value vs. Energy Value and Pulser Voltage Value for DPR300 Units with the 900V Pulse Voltage Option

When a DPR300 instrument with a 900V pulser option is operated in internal-trigger mode, the above PRF limits will always be applied as the Energy and Voltage values are adjusted. However, for such instruments operated in external-trigger mode, the average rate of pulser firing must not exceed the rate specified in the table above. For example, if the energy function is set to value 3 and the pulser voltage is set to value 12, then the PRF index limit is 6. This corresponds to a firing rate of 1250 Hz, and the average rate of trigger pulses sent to the pulser should not exceed this value. Appendix A: DPR300 Specifications

10Pulser

| | |
|---------------------------------------|--|
| Pulse Type | Negative spike pulse. |
| High Voltage Supply | 100V to 475V or 100V to 900V, Precision regulated. Sixteen discrete voltage selections are available over the range in equal increments. |
| Initial Transition (Fall Time) | <5 ns (10-90%) typical for 475V pulsers. |
| Pulse Amplitude | -475V or -900V peak. Amplitude depends on Energy, Impedance, Damping control settings, and pulser type. |

| | |
|-------------------------------|--|
| Pulse Energy | 1.55 μ Joules minimum, 304 μ Joules maximum for 475V pulsers. Dependent upon energy and voltage setting. |
| Pulse Duration | Typically 10-70 ns FWHM for 50 Ω load. Function of the Energy, Impedance, and Damping controls. |
| Damping | 16 Damping values: 331, 198, 142, 110, 92, 77, 67, 59, 52, 47, 43, 39, 37, 34, 32, and 30 Ohms. |
| Mode | Pulse-echo or through transmission. |
| Through Mode Isolation | Typically 80 dB at 10 MHz. |
| Pulser Repetition Rate | Internal: 100 Hz - 5 kHz for 475V pulsers. Limits apply for 900V pulsers. External: 0 - 5 kHz for 475V pulsers. Limits apply for 900V pulsers. |
| Sync Output | Maximum +5 V, $t_r < 30$ ns, $t_w = 50$ ns. min. TTL and CMOS compatible. Minimum value of load impedance is 50 Ω . |
| Pulse Trigger Source | Selectable by computer between internal oscillator and external source. |
| External Trigger Input | 3 - 5 V positive going pulse. Triggering will occur synchronously with leading edge of trigger signal. TTL and CMOS compatible. |

10.1

Receiver

| | |
|-------------------------|---|
| Gain | -13 to 66 dB in 1 dB steps controlled by the host computer. |
| Phase | 0° (noninverting) |
| Input Impedance | 500 Ω (through transmission) |
| Bandwidth | .001 - 35 MHz (-3 dB) or .001 - 50 MHz (-3 dB) |
| High Pass Filter | DC, 1, 2.5, 5, 7.5, and 12.5 MHz. |
| Low Pass Filter | 3.0, 7.5, 10, 15, 22.5 (35 MHz BW) or 5, 10, 15, 22.5, 35 (50 MHz BW) |
| Receiver Noise | Typically 49 μ V peak-peak input referred (measured at 60 dB gain, 35 MHz bandwidth). Typically 59 μ V peak-peak input referred (measured at 60 dB gain, 35 MHz bandwidth). |
| Output Impedance | 50 Ω |
| Output Voltage | ± 5 V into 50 Ω |

10.2

PC or Compatible Control Computer

| | |
|------------------|--|
| Interface | Bi-directional communication via RS-232 serial port using RJ45 type 8-conductor cable. |
|------------------|--|

Software Windows based GUI control program and SDK are provided free.
Windows 2000, Windows XP, Windows Vista, and Windows 7.
LabVIEW VI drivers provided.

10.3 Environmental Conditions

Operating Temperature 0 to 50 °C
Operating Humidity 0 to 80% RH non-condensing

10.4 Miscellaneous

Voltage: 100VAC / 120VAC / 220VAC / 240VAC, 50/60 Hz.
Power 10 W
Dimensions 3.9" High, 8.5" Wide, 12.25" Deep
Weight 5.0 lbs (2.3 Kg)
Operating Temperature 0 to 50 °C
Fuse: .25A 250V 3AG-type slow-blow glass-cartridge fuses

Notes: Specifications typical at 25 °C